

Sink Diade

Kitchen Sinks

Code: 3028 555



DETAILS

Edge/Installation Type Phantom Base

Material AISI 304 stainless steel

Texture Brushed in line

Finish Foster brushed

Base 90 cm

Width 80 cm

Dimensions 824 x 464 mm

Bowl dimension 760 x 400 mm

Built-in hole [View technical data sheet](#)

Standard fittings Drain, Foster overflow and universal corrugated pipe (for installing different overflows), Boxed packing

Mixer holes No standard holes

Drainer No

Number of bowls 1 bowl

Waste fitting 3,5" drain

Notes: Cad 3D geometries can be provided on request to make grids and sink in the same material as the worktop

FEATURES

Basket 3,5" waste fitting The drain is equipped with a large 3.5" drain, with the practical basket cap that prevents the discharge of solid parts.

Deep bowls This bowls reach an important depth, over 20 cm, thanks to the advanced production technology, that can be offer great capieny and practicity in all the washing operations.

High thickness 1mm thick steel. A significant thickness, which guarantees the maximum sturdiness and durability.

MOULDED BOTTOM The moulded bottom guarantees perfect water flow and facilitates cleaning operations thanks to the perimeter step with sloping walls.

Perimetral overflow The overflow is always a security on the Foster sinks that prevents the overflow of water in case of oversights. The perimeter drain solution improves aesthetics thanks to its square and essential shape.

TECHNICAL DATA

Phantom Base
Base 90 | 90 Cabinet

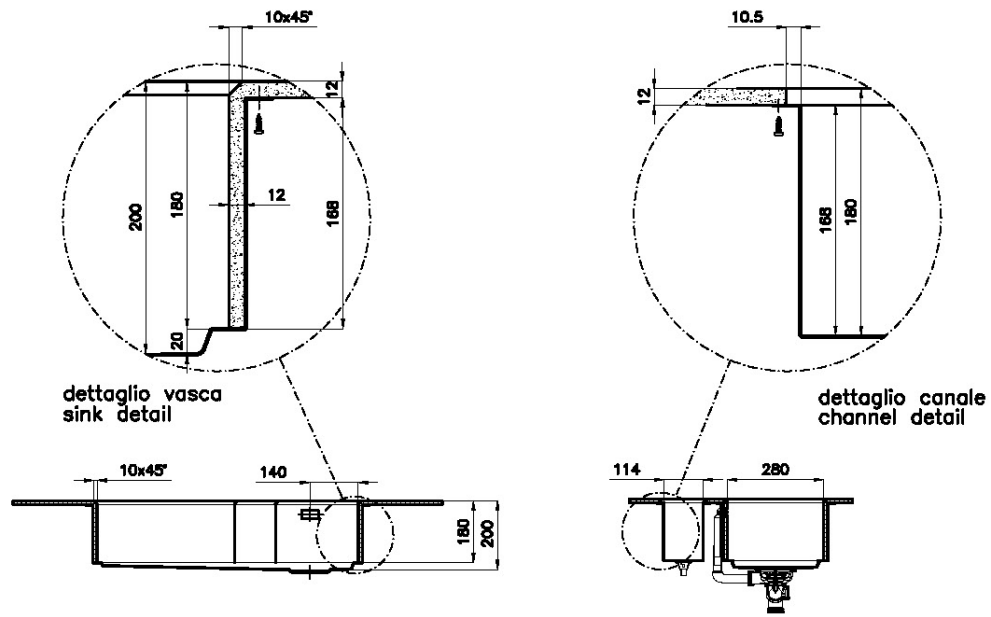

dettaglio vasca
sink detail

dettaglio canale
channel detail

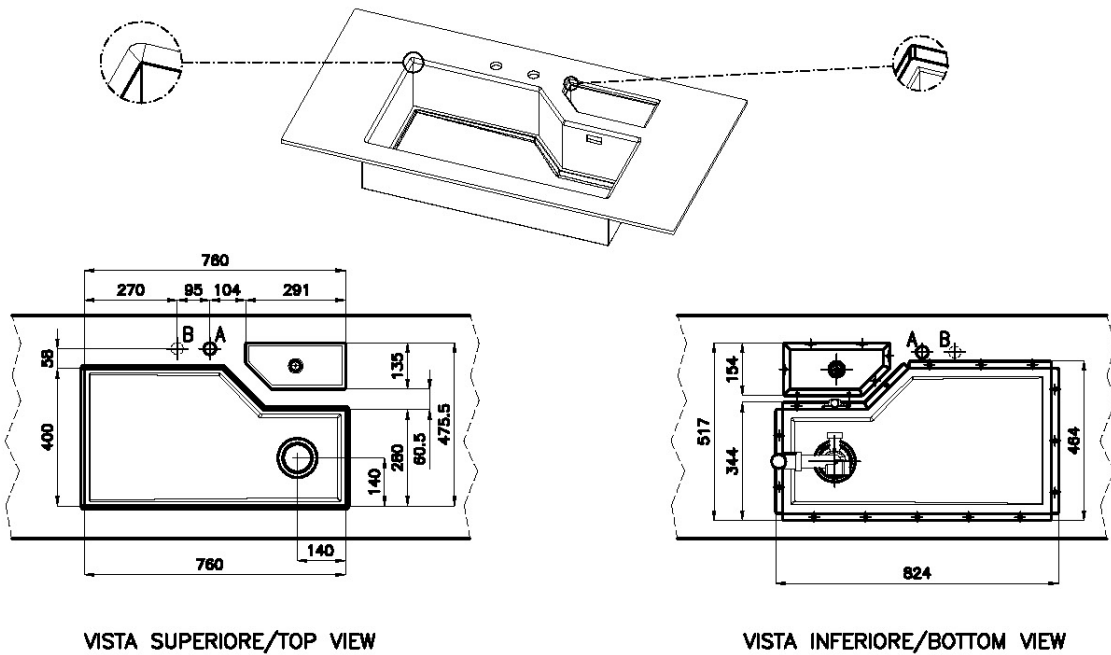

VISTA SUPERIORE/TOP VIEW

VISTA INFERIORE/BOTTOM VIEW

A: Foro Mix/Mixer tap cut-out

B: Foro comando automatico pileta/Automatic waste-fitting command cut-out

Disponibili geometrie CAD 2D e 3D / 2D and 3D CAD geometries available

Phantom Base
Base 120 | 120 Cabinet

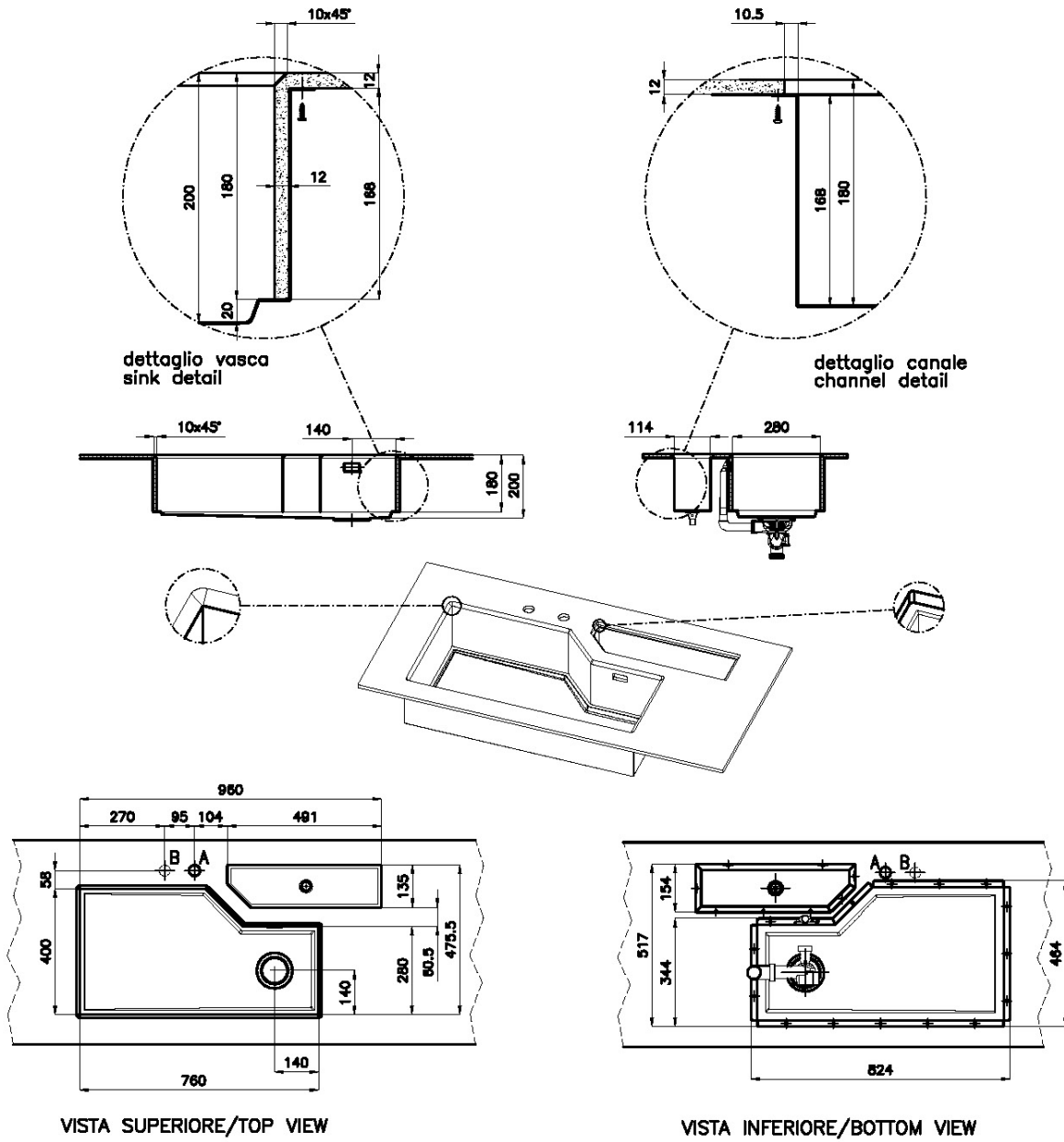

A: Foro Mix/Mixer tap cut-out
 B: Foro comando automatico piletta/Automatic waste-fitting command cut-out
 Disponibili geometrie CAD 2D e 3D / 2D and 3D CAD geometries available

Phantom Base

Base 90 | 90 Cabinet

DISEGNI VASCA INOX / STAINLESS STEEL TUB DESIGNS

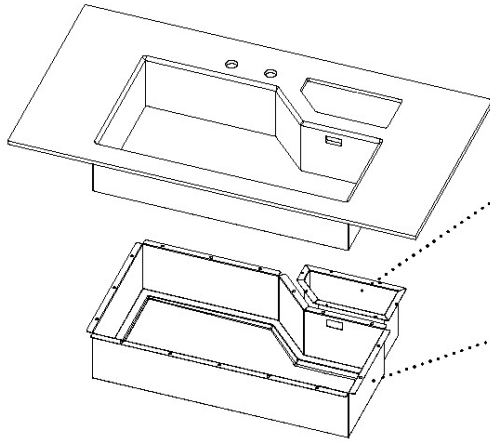

sink thickness/spessore acciaio

1

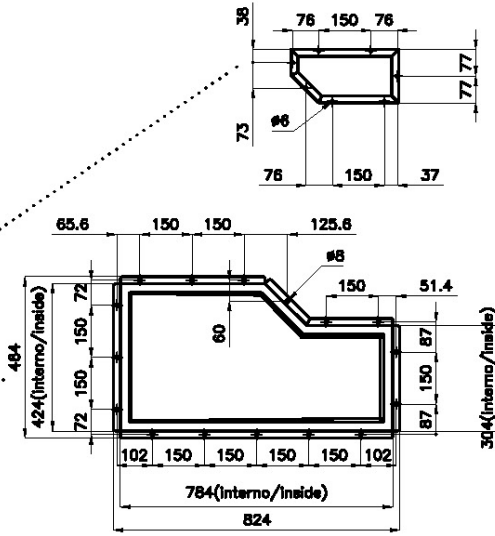

DISEGNI PER COSTRUZIONE TOP DRAWINGS FOR TOP CONSTRUCTION

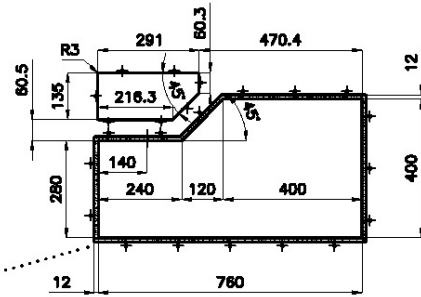
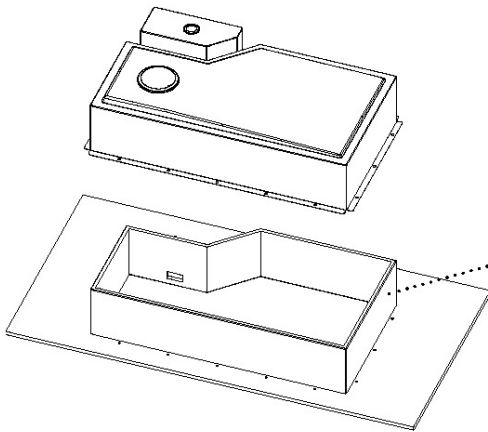

VISTA INFERIORE/BOTTOM VIEW

Posizione fori
Holes position

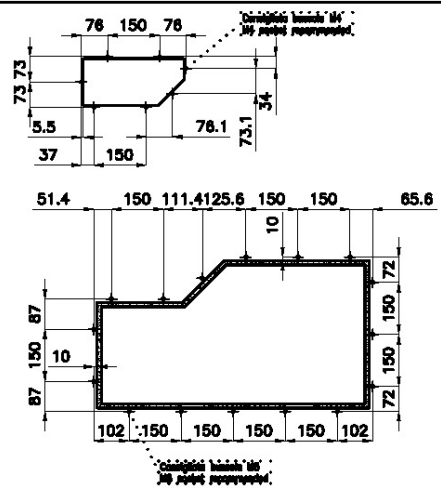

DETALIO PER TROPPO PIENO / OVERFLOW DETAILS

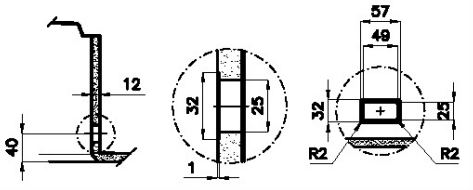

Phantom Base

Base 120 | 120 Cabinet

DISEGNI VASCA INOX / STAINLESS STEEL TUB DESIGNS

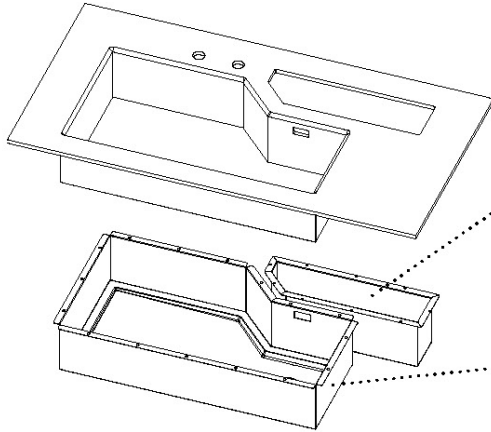

sink thickness/spessore acciaio

1

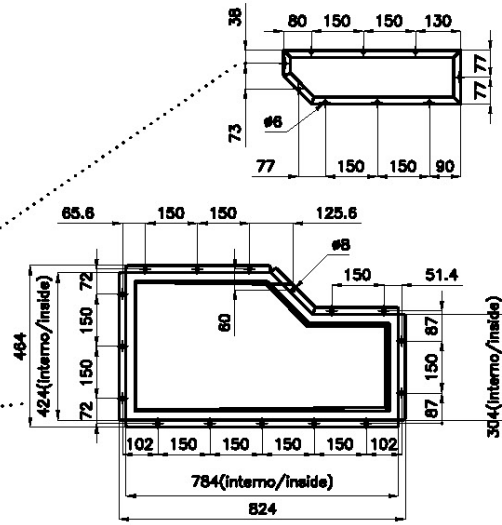

DISEGNI PER COSTRUZIONE TOP DRAWINGS FOR TOP CONSTRUCTION

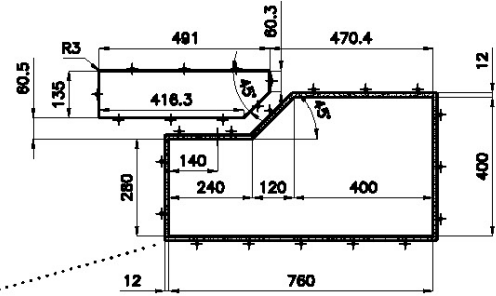
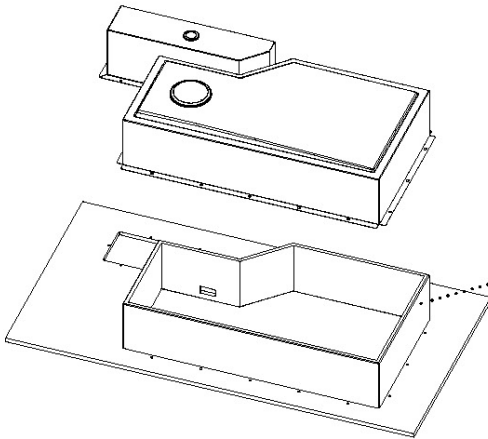

VISTA INFERIORE/BOTTOM VIEW

Posizione fori
Holes position

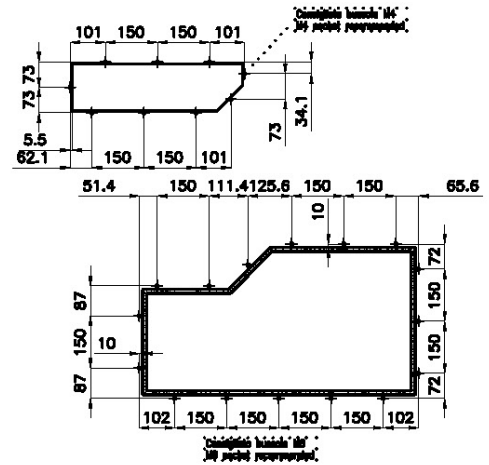

DETALIO PER TRONCO PIEDI / CHINFLOW DETAILS

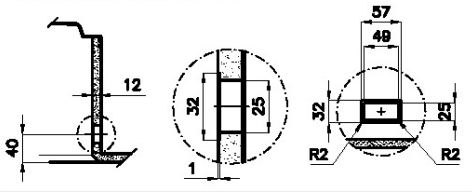

PHANTOM

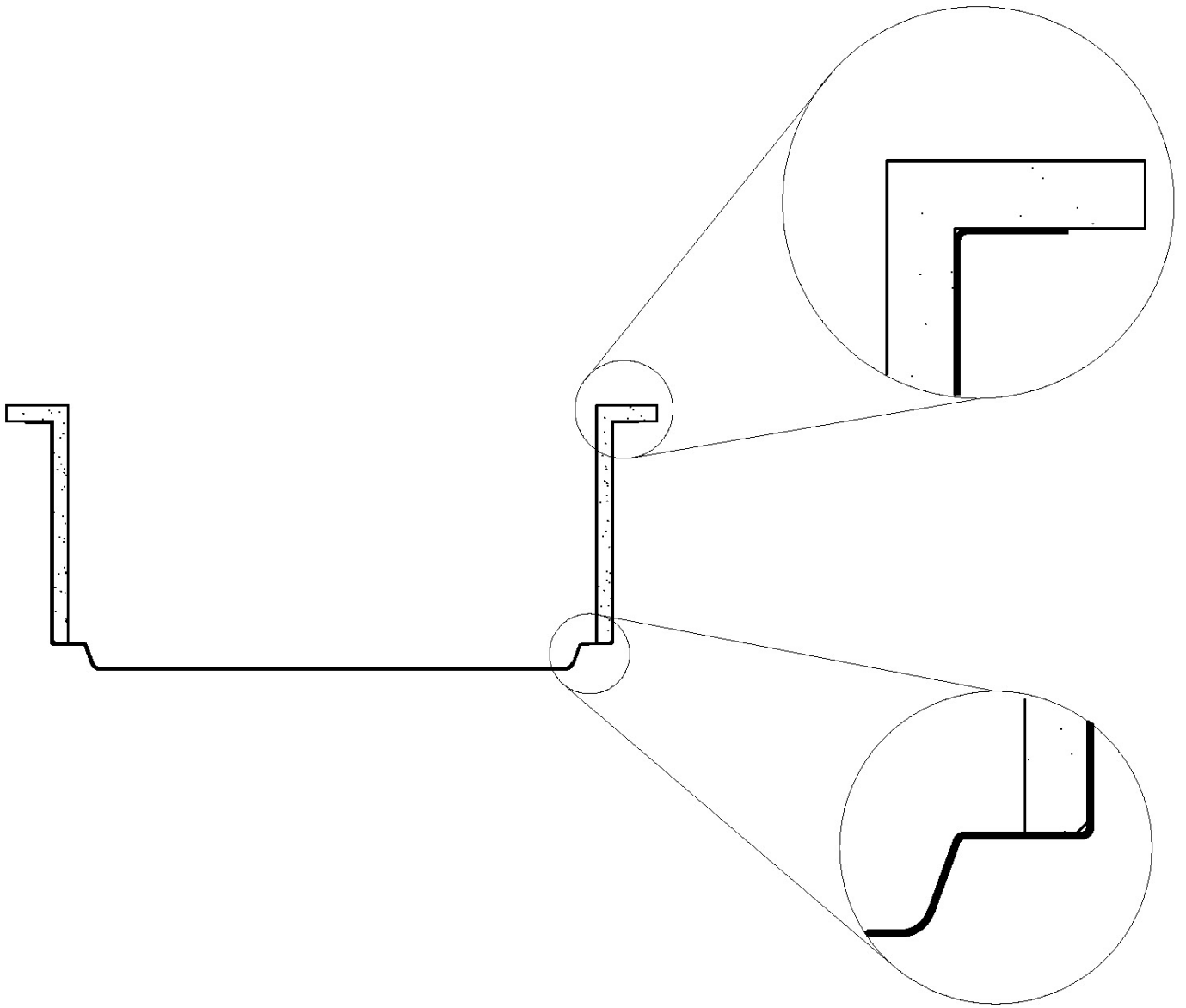

GALLERY

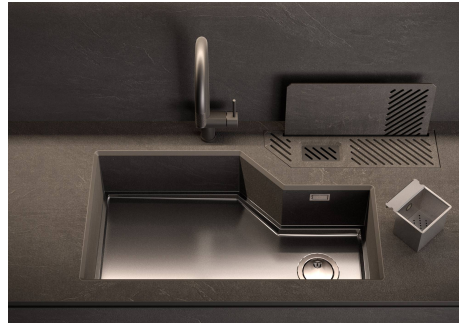

EQUIPMENT



**Black multifunction chopping
board**

8100 608

OPTIONAL ACCESSORIES



Stainless steel perforated tray
8151 001



Black lid
8151 005



Stainless steel colander
8151 010



Iroko-wood round chopping board
8642 005

RECOMMENDED PAIRINGS



VOLTA
8491 100



Dispenser Evo Satin
8520 100



Diade equipped troughs Phantom
8100 003



Diade equipped troughs Phantom
8100 004



Diade equipped troughs Phantom
8100 005

OPTIONAL AUTOMATIC WASTE FITTINGS



Space Push automatic waste fitting
- PP
8407 116